



## **EHC™ FOR CVOCs - RECOMMENDED BASELINE SAMPLING**

### **Summary**

This document provides guidelines for baseline sampling prior to injection of EHC™. The baseline would ideally consist of the following analyses in the treatment zone monitoring locations installed prior to injection:

#### **Critical Parameters:**

- Chlorinated Volatile Organic Carbons, CVOCs
- pH
- Dissolved Oxygen, Redox Potential (Eh)
- Metals Scan (iron, calcium, magnesium, manganese included)
- Anion Scan (chloride, sulfate, nitrate included)
- Total Organic Carbon, TOC

#### **Non-Critical Parameters:**

- Dissolved Organic Carbon, DOC
- Biological Oxygen Demand, BOD
- Chemical Oxygen Demand, COD
- Alkalinity
- Hardness
- Volatile Fatty Acids, VFAs
- Dissolved Gases (ethene, ethane, methane, hydrogen)

Critical parameters are used to assess the applicability of an ISCR approach, and they can establish a baseline for potential secondary plume constituents (e.g. heavy metals). The non-critical parameters are optional, but they provide general information about the soil and water chemistry which may be useful when analyzing the results.

### **General Soil and Groundwater Chemistry**

At a minimum, we recommend measuring pH, Eh, metals, anions and TOC to evaluate the conditions within the impacted area. These will help us to establish the loading requirements and to select the appropriate EHC product. In addition, DOC, BOD, COD, alkalinity and hardness would be recommended to provide general information about the soil and groundwater chemistry.

### **Constituents of Interest and Related Daughter Products**

The concentration of the constituents of interest and their related daughter products within the treatment area are essential for both the remedial design and post-injection evaluation. The presence of daughter products indicates ongoing natural attenuation and will help to estimate the redox state of the aquifer.

Anaerobic degradation pathways for chlorinated ethenes, ethanes and methanes:

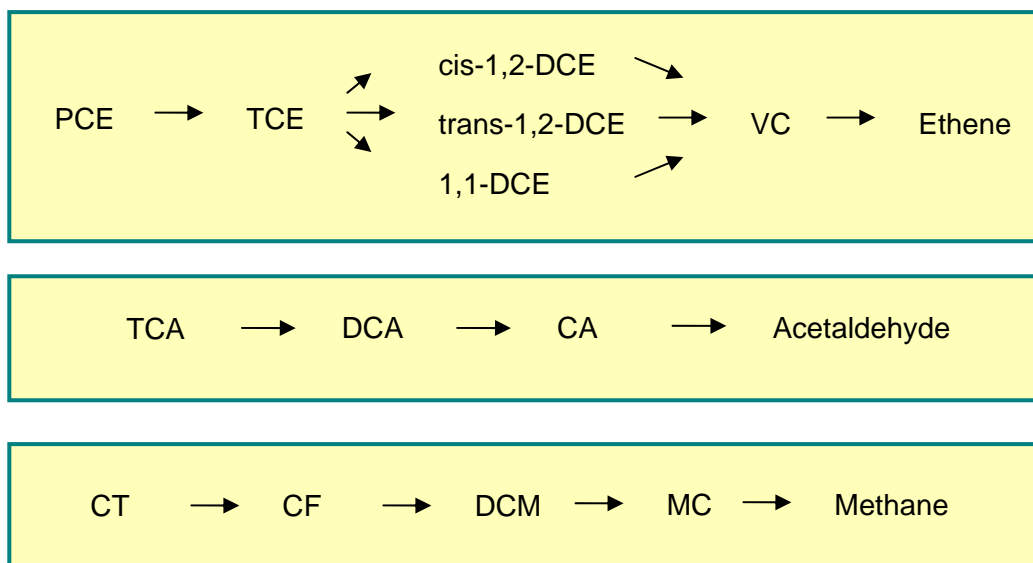

### Competing Electron Acceptors

The level of competing electron acceptors will affect the loading requirements for EHC. In addition, the concentration of these could be used to estimate the redox state of the aquifer. In general the natural electron acceptors will be utilized in the following order:

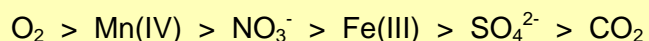

### End Products

Elevated levels of chloride and degradation end products (ethene/ethane/methane) indicate complete reductive dechlorination. Baseline levels could be compared to background levels (outside of plume area) to evaluate if natural attenuation is already occurring or to post-injection levels to evaluate the effect of EHC.

### EHC Breakdown Products

Baseline TOC, DOC, VFAs and Fe data could be compared to post-injection levels to determine that the groundwater is in fact under the influence of EHC. Elevated levels of these parameters would indicate effective product placement. Elevated levels of TOC, DOC and Fe would be expected almost immediately following the EHC injection. As the organic carbon gets degraded by the indigenous bacteria, elevated levels of VFAs would be expected.

### For more information, contact us at:

Adventus Remediation Tech.  
1345 Fewster Drive  
Mississauga, ON  
Canada L4W 2A5  
Ph: 905.273.5374  
Fx: 905.273.4367

Adventus Americas Inc.  
2871 W. Forest Rd, Ste 2  
Freeport, IL 61032  
USA  
Ph: 815.235.3503  
Fx: 815.235.3506

EnviroMetal Technologies  
745 Bridge Street W. Ste 7  
Waterloo, ON  
Canada N2V 2G6  
Ph: 519.746.2204  
Fx: 519.746.2209